

Old Sparky

created/diagrammed by Alec Fehl 7/24/00

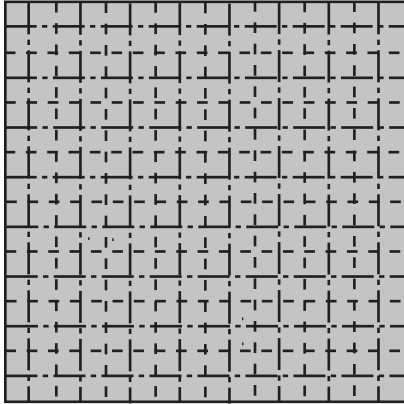

1] Precrease 16ths. Note center is valley.

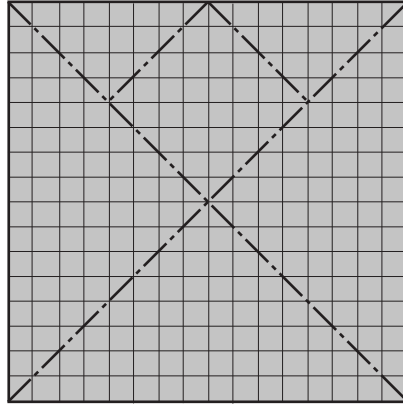

2] Mountain diagonals and mini-diagonals.

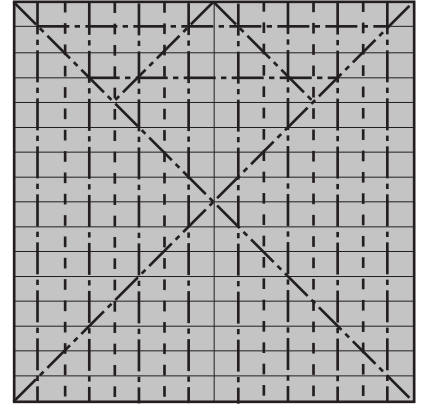

3a] Collapse left side. See next step for detail...

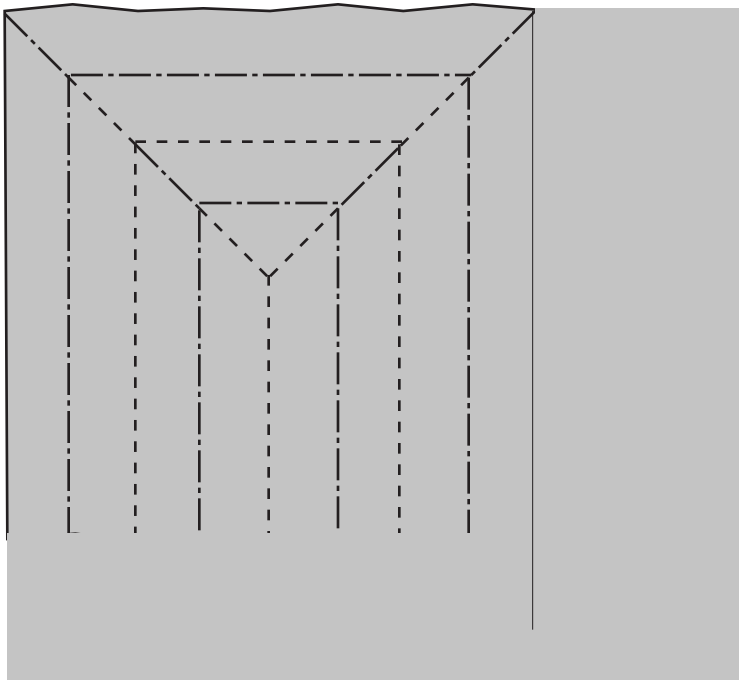

3b] Close up of collapse.

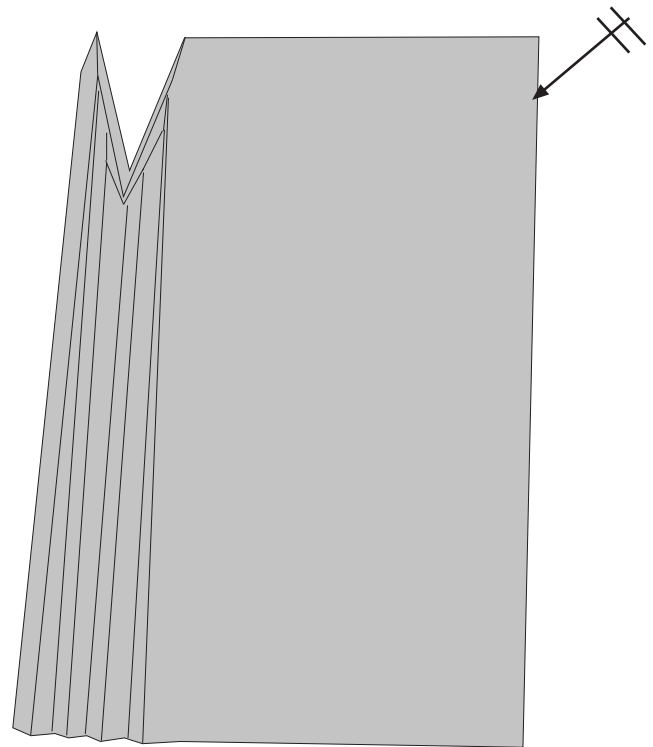

4] Looks something like this. Repeat on right.

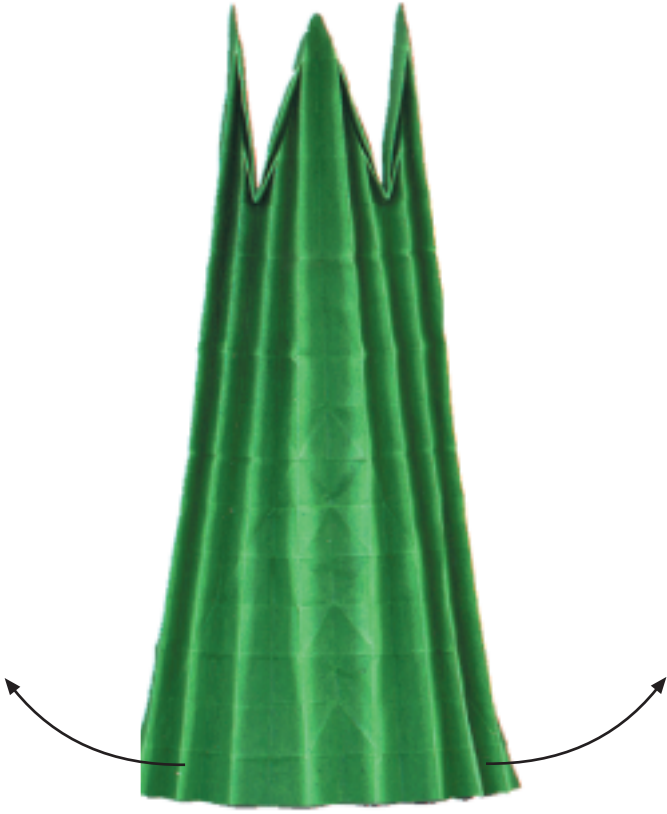

5] Looks like this. Spread apart bottom.

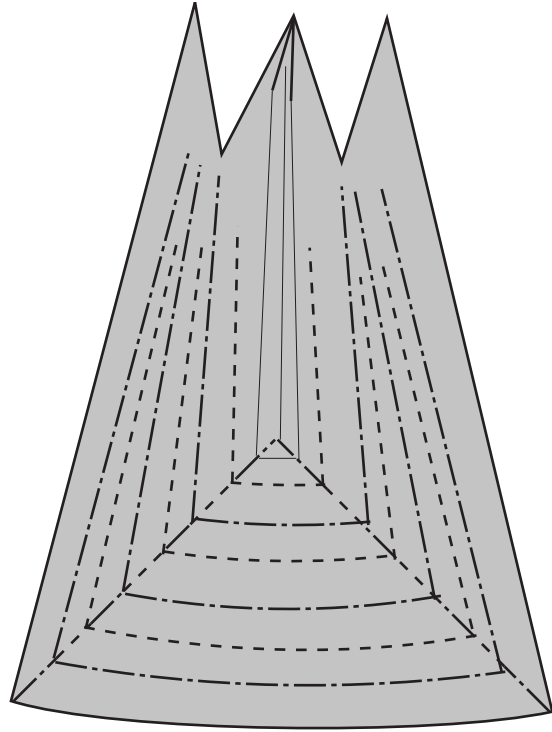

6] Collapse on creases.

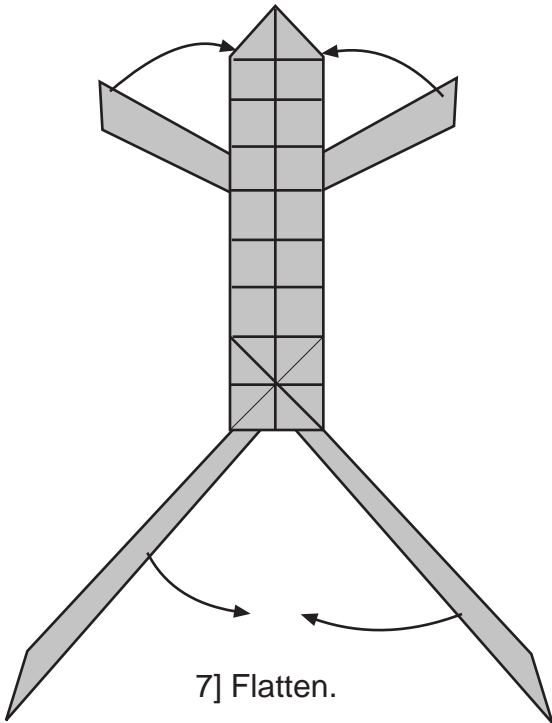

7] Flatten.

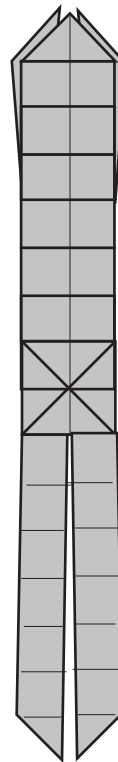

8] Turn over.

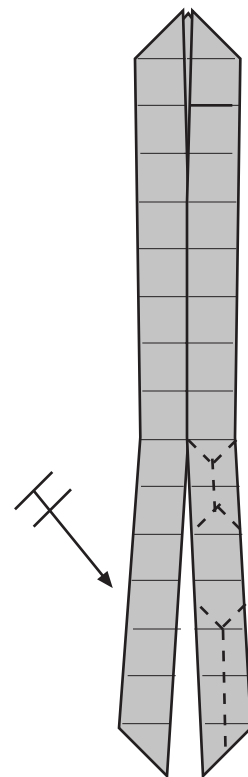

9] Rabbit ear 3 times. Repeat on left.

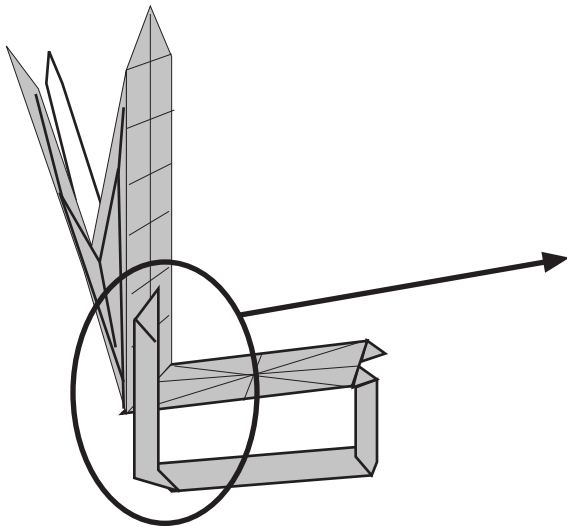

10] Focus on the back leg.

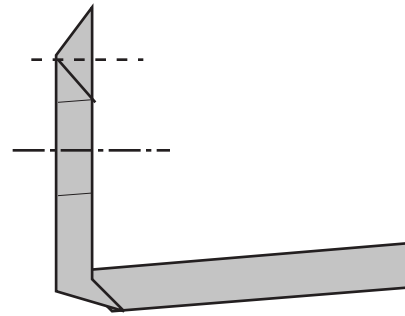

11] Valley tip. Mountain between existing creases.

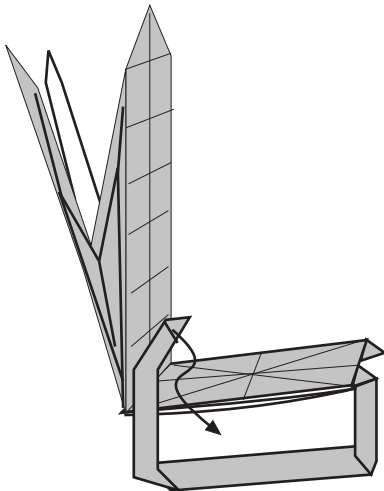

12] Tuck inside middle layer or seat. Repeat on other leg.

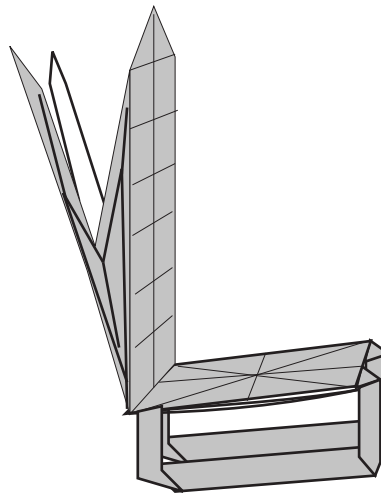

13] Flip chair over.

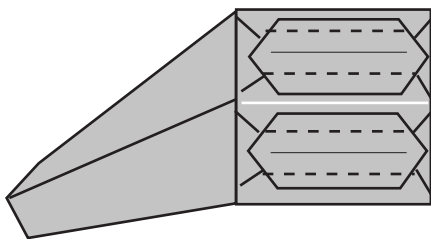

14] Thin bottom of legs, then...

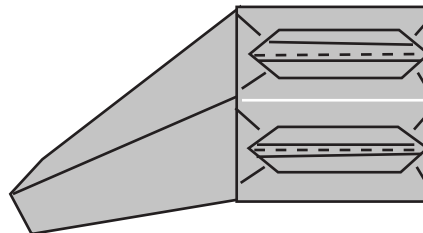

15] Fold in half.

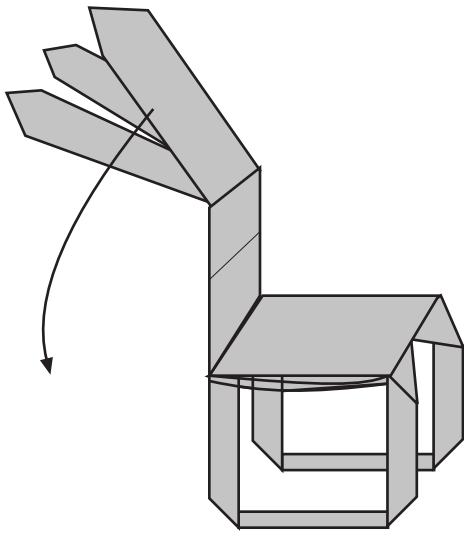

16] Fold down.

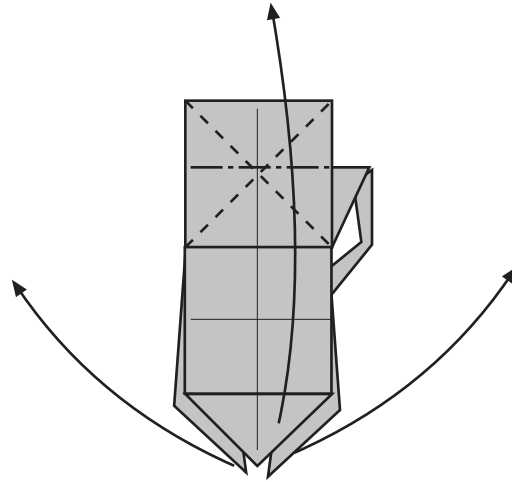

17] Water-bomb top layer and allow 2 flaps to slide out.

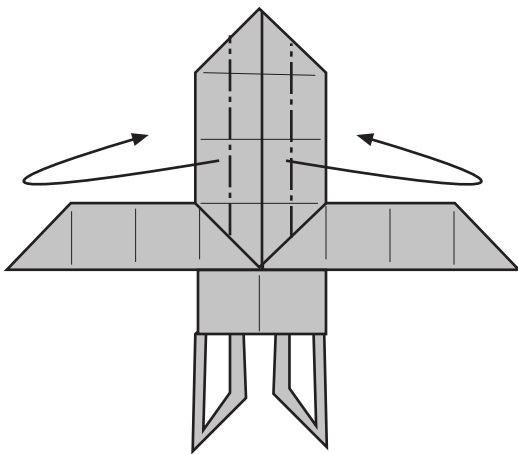

18] Mountain flap to thin.

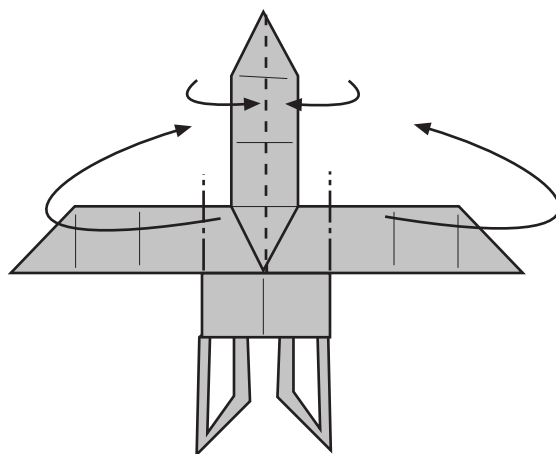

19] Mountain arms over. Valley (pinch) top flap.

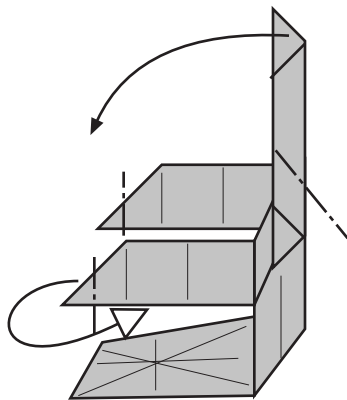

20] (Legs not shown.) Outside reverse top. Inside reverse fold tips or arms 1/2 way.

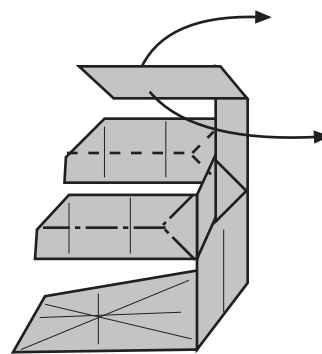

21] Rabbit ear arms. Pinch them very tight so they overlap back of chair. This will help to lock them in place. Pull flaps out of top and mold 'helmet'.

